

EZ25

Tracked Zero Tail Excavators



**WACKER
NEUSON**
all it takes!



The design for champions

The compact excavator EZ25 guarantees modern design, flexibility and ease of use. A reliable excavator for secure, comfortable and fatigue-free operations with high comfortable handling. The wide cabin entry and the arrangement of control and display elements of the EZ25 are ergonomically perfectly adapted to the needs of your workplace. Due to the short rear end, the EZ25 can be used besides obstacles without any limitation of its movement.

- The re-designed cabin of the EZ25 is ergonomically optimized and spacious with easy access for the operator.
- Thanks to its factory-installed two-way auxiliary hydraulic lines the EZ25 is ready for hydraulic attachments, like the hydraulic breaker.
- Robust design, low maintenance efforts and high productivity for cost minimized operations and maximal fuel efficiency
- Zero tail swing for working in tight and confined spaces
- Durable and secure construction of every nut, bolt and screw

EZ25 Technical specifications

Operating data

Shipping weight min.	2,560 kg
Operating weight	2,710 - 2,755 kg
Biting force max.	15.3 kN
Breakout force max.	22.5 kN
Digging depth max.	2,537 mm
Digging radius max.	4,624 mm
Superstructure slewing speed	10 1/min
L x W x H	4,266 x 1,570 x 2,414 mm
Tank capacity	36 l
Engine / Motor	
Engine / Motor manufacturer	Yanmar
Engine / Motor type	3TNV76
Displacement	1,116 cm ³
RPM / speed	2,500 rpm
Engine performance output to ISO	15.8 kW
Battery	44 Ah
Hydraulic system	
Duty pump	double variable- & two-gear pump
Max. flow rate	30.5 + 30.5 l/min
Max. flow rate	20.2 + 7.5 l/min
Operating pressure for working and traction hydraulics	225 bar
Operating pressure slewing gear	206 bar
Undercarriage	
Travel speed max.	3.8 km/h
Chain width	300 mm
Ground clearance	277 mm
Dozer Blade	
Width	1,570 mm
Height	300 mm
Stroke max. above ground	387 mm
Stroke max. below ground	412 mm
Sound level	
Sound level (LwA) acc. to 2000/14/EC	93 dB(A)
Cabin - specified sound pressure level LpA acc. to ISO 6394	79 dB(A)

EZ25 Dimensions

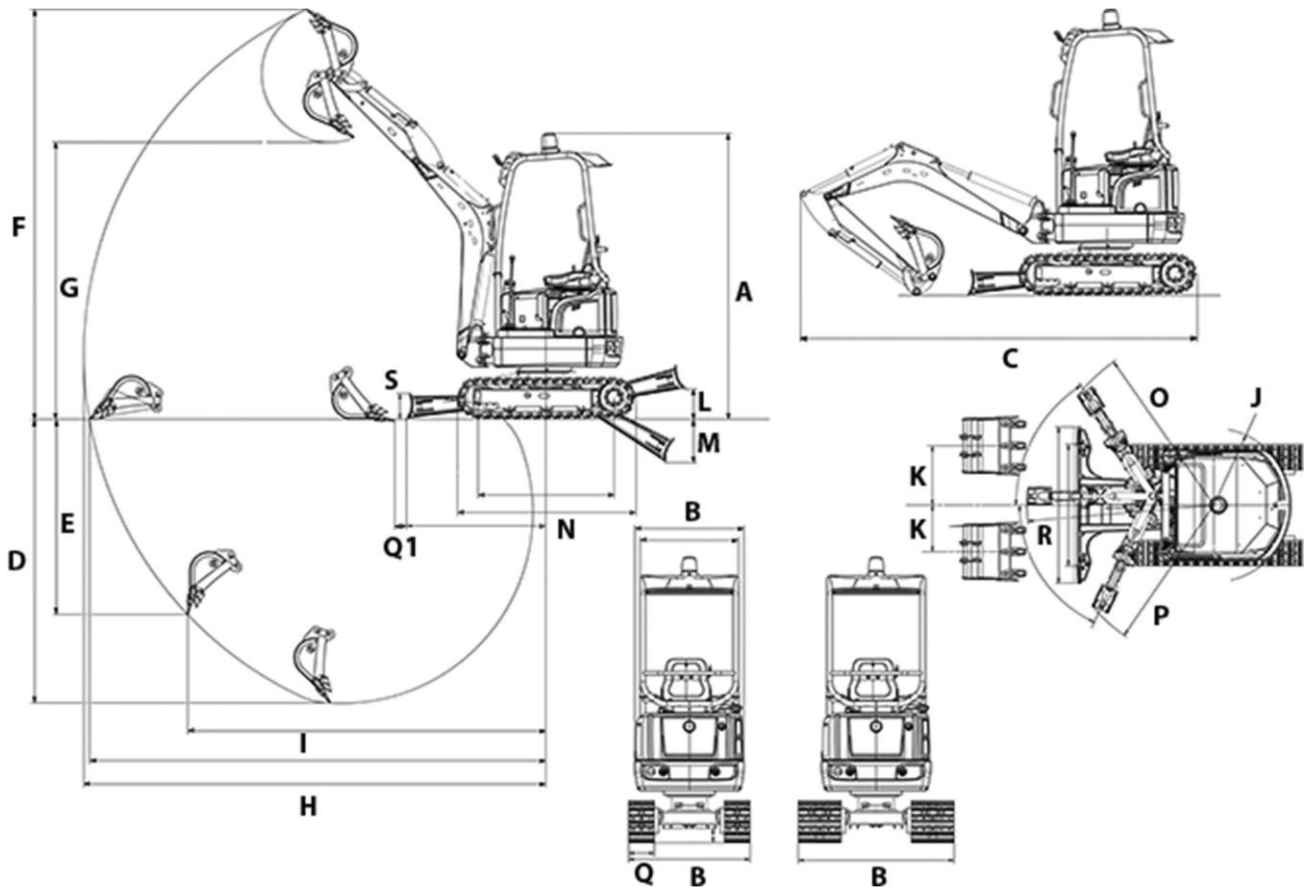

A	Height	2,414 mm
B	Width of the cabin	986 mm
B	Width of the revolving superstructure	1,366 mm
B	Width of the undercarriage	1,570 mm
C	Transport length (short DA)	4,266 mm
D	Digging depth max. (short DA)	2,537 mm
E	Insertion depth max. vertical (short DA)	1,949 mm
F	Insertion height max. (short DA)	4,176 mm
G	Dump height max. (short DA)	2,847 mm
H	Digging radius max. (short DA)	4,624 mm
I	Range max. ground coverage (short DA)	4,490 mm
J	Rear swivel radius	770 mm
K	Arm displacement max. boom offset to center of bucket, right side	765 mm
K	Arm displacement max. boom offset to center of bucket, left side	531 mm
L	Lift height max. of dozer blade above subgrade	387 mm
M	Scraping depth max. of the dozer blade below subgrade	412 mm
N	Length	2,021 mm
O	Turning angle max. of the arm system to the right	50 °
P	Turning angle max. of the arm system to the left	75 °
Q	Chain width	300 mm

R	Boom slewing radius center	2,082 mm
--	Boom slewing radius right	1,964 mm
--	Boom slewing radius left	1,660 mm
--	Distance of bucket dozer blade (short DA)	267 mm
--	Length total traveling gear	2,021 mm
--	Width dozer blade	1,570 mm
--	Height dozer blade	300 mm

DA = dipper arm

Please note: that product availability can vary from country to country. It is possible that information / products may not be available in your country. More detailed information on engine power can be found in the operator's manual; the stated power may vary due to specific operating conditions. Subject to alterations and errors excepted. Applicable also to illustrations.

Copyright © 2022 Wacker Neuson SE.