



**WACKER
NEUSON**

EZ17
Zero Tail Excavator
1.7 t operating weight



**WACKER
NEUSON**



www.wackerneuson.com

Compactness in top form.

The new EZ17.

Sometimes less is definitely more,
especially if it gets tight.
The EZ17 redefines the working radius.

MORE PERFORMANCE ON SMALLEST SPACE.

"The Zero Tail Model EZ17 of Wacker Neuson completely rounds out the spectrum of compact excavators in the weight class between 1-2 tons. In doing so the EZ17 sets new standards for compactness, performance and weight, but also in terms of easy handling, service access and operating comfort it is taking a new direction. Simply less in top form."

Adolf Pernkopf
Wacker Neuson Product Manager



EZ17

Full operating power on smallest space. And everything you need in the tough daily routine.

Canopy with top window. So you never lose orientation, especially when loading. The canopy can be easily demounted as needed.

Large volume diesel engine and efficient cooling system. When you are working, you simply want to work and do so precisely without keeping an eye on the thermometer. 45° surrounding temperature is no reason to do so without performance.

Load-sensing hydraulics system with variable displacement pump. Guarantees the optimal coordination of all movements and full utilization of the existing performance. This makes easy handling even simpler and increases energy efficiency.

Tight work conditions are its speciality. The compact dimensions and the robust Zero Tail design make the EZ17 an extremely agile and highly maneuverable compact machine with a long useful life.

Double action additional hydraulic unit as standard equipment. This vastly expands the range of EZ17 applications.

Optional auxiliary control circuits available ex-works. Up to 4 control circuits increase the working clearance of the EZ17.

EASY LOCK – quick hitch system. Ready for any new task within 30 seconds.

Different attachments. Because flexibility makes work performance more efficient.

Telescopic undercarriage and folding blades. For high stability and extreme agility even in confined spaces.



EZ17

For everyone who wants more output in the heat of the daily action: The engine power of the EZ17 is the cool sibling of efficiency.



The EZ17 is a real miracle of power and space. Everything is installed on smallest space here but without leaving power and backup reserves to be missed. This adds to work satisfaction. Because the large volume diesel engine and the new cooling system promise high performance and efficiency also in high surrounding temperatures of up to 45 °C. This way you will always get the best out of any job.

Cooling system

Fuel tank

Hydraulic fluid tank

Drive unit

Hydraulic valves

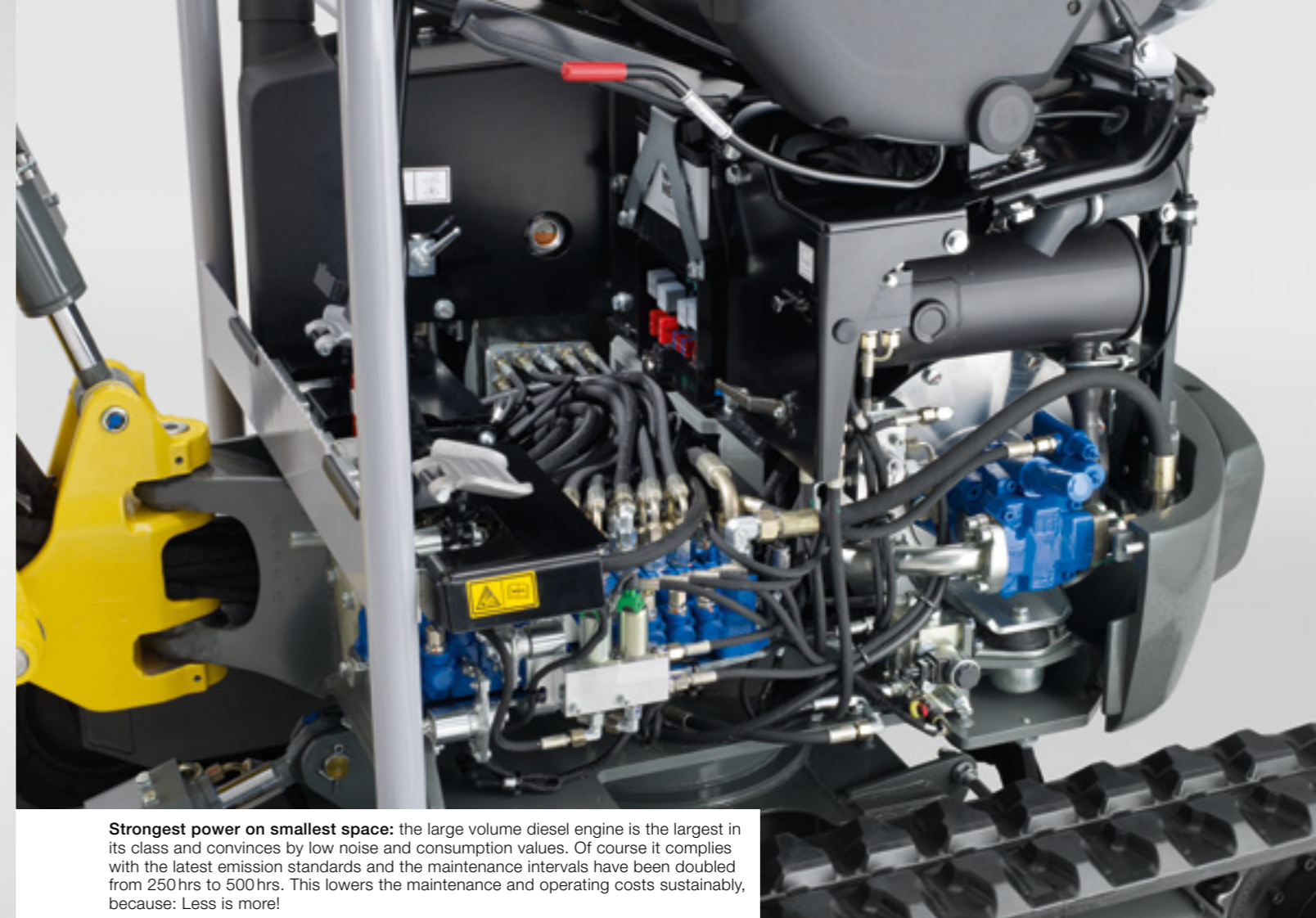
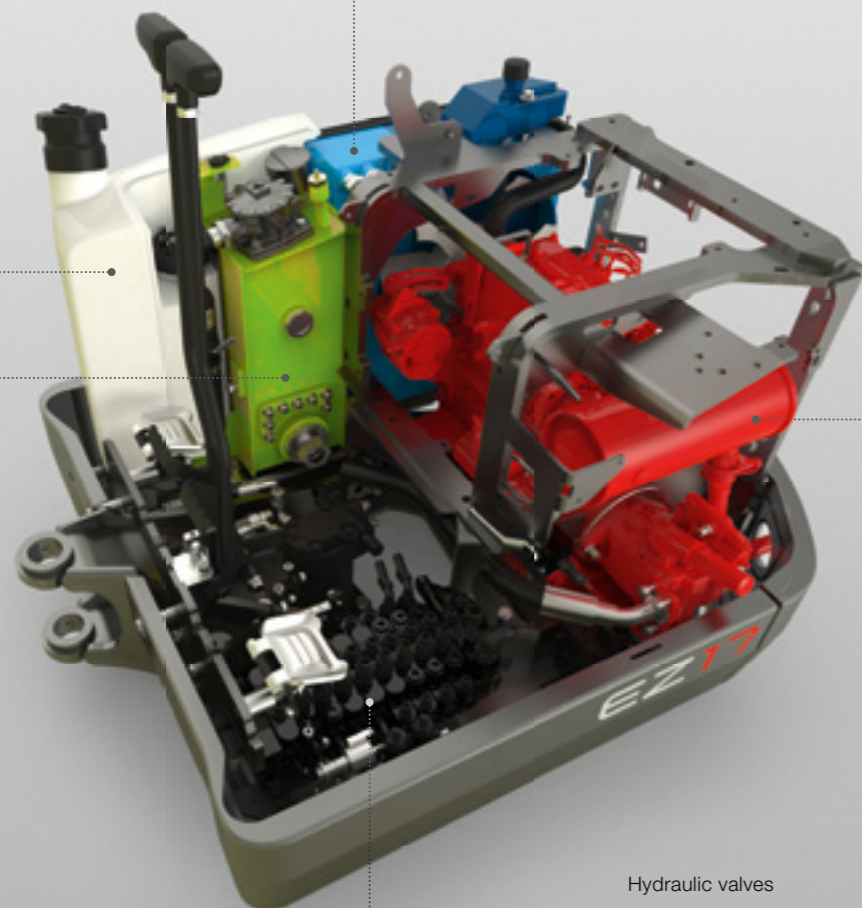

Strongest power on smallest space: the large volume diesel engine is the largest in its class and convinces by low noise and consumption values. Of course it complies with the latest emission standards and the maintenance intervals have been doubled from 250 hrs to 500 hrs. This lowers the maintenance and operating costs sustainably, because: Less is more!

1 Hydraulics with LUDV – Load Sensing System and variable displacement pump.

This enables finely tuned movements of the excavator and full utilization of the existing performance for easier handling. The combination with the variable displacement pump makes for a very energy efficient system. The EZ17 quite simply changes your workflow to the better.

2 Longer useful life, cooler and absolutely wear-resistant.

The EZ17 features an innovative cooling system that ensures extremely high thermal resistance by virtue of a newly developed coolant air circuit. This permits working at full load in surrounding temperatures of up to 45°C. The generally lower temperature level in the entire hydraulics system ensures a longer useful life of all components. The cooler completely made of metal can be accessed easily and with its wide mesh and very stable cooler lamellas it can be cleaned just as easily. This extremely robust design additionally minimizes the risk of damages.



1



2

EZ17

Flexible performance is what matters today on the construction site. Therefore, the EZ17 is also prepared perfectly for this purpose.



The EZ17 does not only develop its efficiency on smallest space because of its compact dimensions but foremost due to the combination of its high-performance drive, the innovative hydraulics and its strong arm system. Therefore, we offer the EZ17 also with two different dipper stick lengths. This is effective digging power on a new and compact level.

Full safety and best protection. The hose guide from the lifting arm to the chassis runs on the inside and is led through a two-piece pivot console. The lifting arm cylinder is positioned on the top side and therefore offers the optimal protection for the piston rod. This way, you are always at work with full safety.

Additional weight in use. The easily mountable counter-weight provides the EZ17 with additional stability and protection in the rear section.



1 Maximum flexibility on the transport gear:

With an extremely stable telescopic undercarriage even the narrowest of passages become easy as child's play. At the same time, stability is always guaranteed.

2 Robust, practical, folding:

The folding blade expansions that are extremely torsion-resistant ensure easy handling and are installed fixed on the transport gear. They will not be forgotten at the construction site again.



Additional plus in safety. The optional hose rupture safety valves make the operation still safer.

Short or long – you decide. With the strong arm system using two optionally selectable dipper arm lengths, the optimal shear and digging values will be reached at all times with the EZ17.

Optional for up to 4 auxiliary control circuits. The EZ17 is equipped with a double action control circuit as a standard. Optionally, up to 4 additional control circuits can be delivered ex-works.

An arm system with future perspective. The bend of the lifting arm was adjusted to the geometry of the EZ17 and is ready for adding on more options.

Options for more working clearance: The EZ17 is optionally available with PowerTilt and EASY LOCK.

EZ17

Flexibility and function is a promise of many. But what really works in practice is only proven in the actual use on the construction site.



Functionality increases productivity in daily use, this is why we have built the EZ17 with a focus on practical application so that you can always do an efficient job. Equal, whether in quick transport from A to B, simply lifting the machine or demounting the canopy. With the EZ17 you decide for high functionality in the tough routine at the construction site.



4 screw points

1

1 Simple demounting for extremely low head rooms.

Sometimes the canopy just has to be demounted, even if doing so is not permitted in the ultimate work operation. The canopy can be demounted easily with just 4 screws while all machine functions remain preserved. At the place of use it is mounted back on in no time.

2 Additional weight in use.

The easily mountable counter-weight made of massive cast steel provides the EZ17 with additional stability and protection in the rear section.

2



Arrive quickly at a new place of use: The lifting eyes integrated in the canopy enable simple and quick moving or loading of the machine by means of the practical two-point suspension.

EZ17

Everything has been thought of from the start in the design of the EZ17: That is why it has a square shape, is practical and easy to service.



The EZ17 redefines suitability for daily use. With a wrench size 17 the most important components can be demounted at the construction site and everything can be taken off, reached and checked conveniently. Maintenance and disassembly have never been as simple as today with the EZ17. Because it is also true on the construction site: Time is cash.

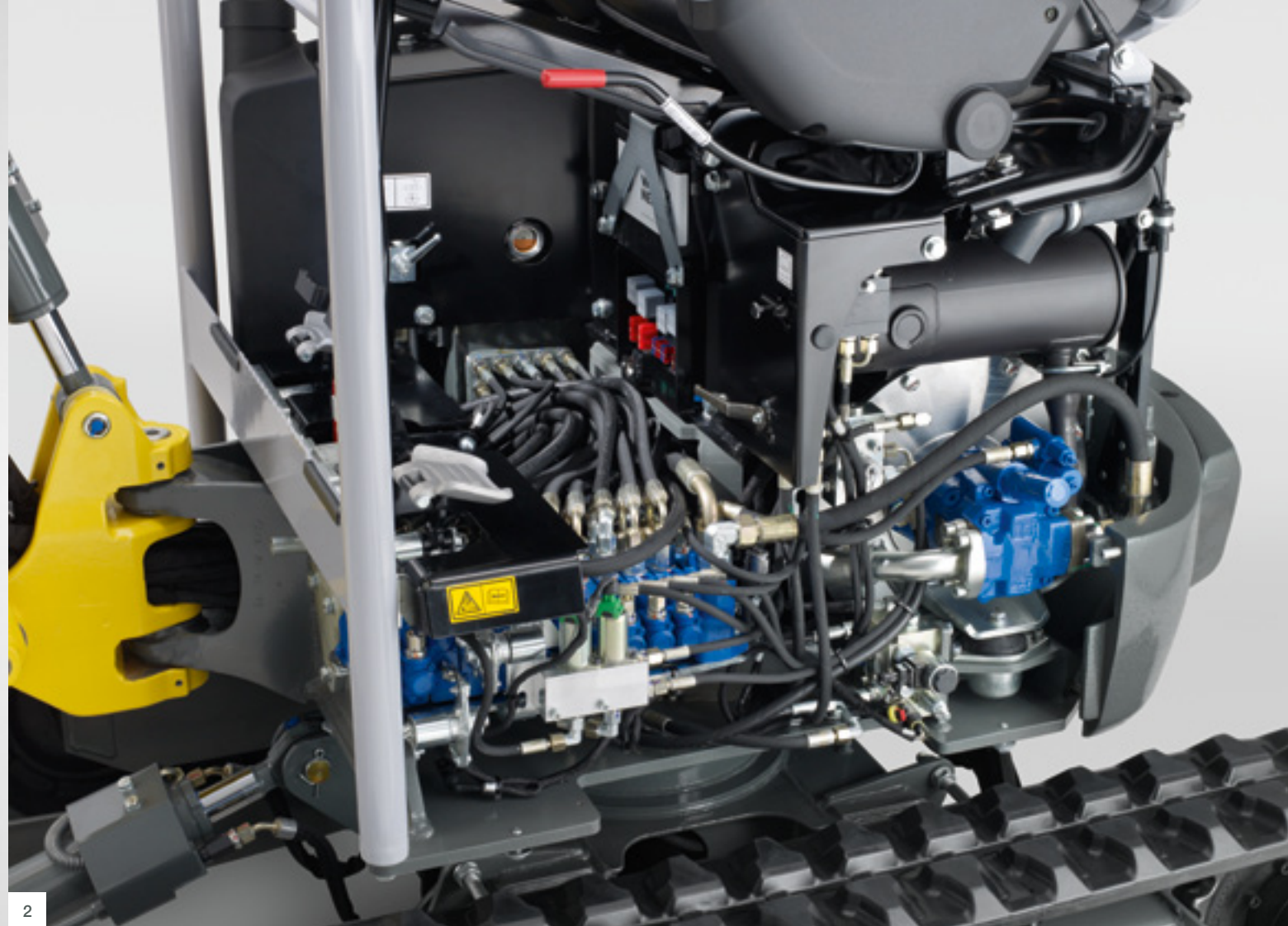

2

One size fits all. With a wrench size 17 you have all maintenance tasks under control.

Because time is cash we designed the EZ17 in such a way that the maintenance effort is practically reduced to a minimum. This starts with the maintenance interval that has been doubled to 500 operating hours and is completed with the individual components that can be demounted and mounted with a wrench size 17. But see for yourself.



1

1 Open the lid for rapid service.

The rear lid of the EZ17 guarantees easy maintenance access to filter elements and service.

2 Simple demounting for quick access.

The two chassis covers on the side can be demounted simply by means of a wrench size 17 and enable easy access to the chassis components.

3 Simply fold them away and perform the maintenance.

The driver's seat can simply be flipped over with one grip for servicing components such as the alternator and starter.

4 Quickly obvious hydraulic oil level.

The hydraulic oil level can be quickly and easily checked on the sight glass in the footwell of the EZ17.

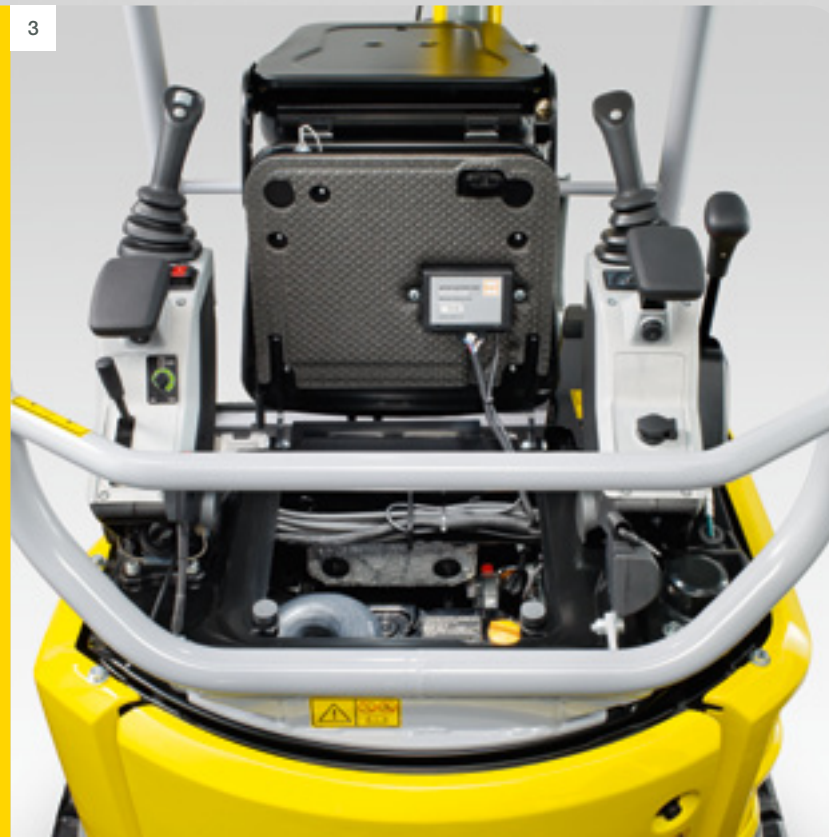

3



4



EZ17

Those, who work a lot, appreciate three things: The perfect overview, full control and the certain extra in comfort.



In this sense, the canopy of the EZ17 sets new standards in overview, safety, leg room and operating comfort. Everything is at the right place. Nothing blocks the sight of what is essential. Fatigue-free, comfortable and focused work therefore finally becomes reality.

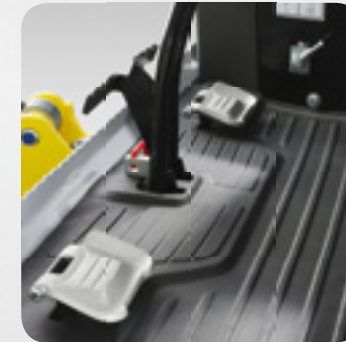

Everything in clear sight and under control. The modular control lever stays allow for a completely new operating concept with the greatest level of clarity and safety. Everything is within reach here and is clearly arranged through the perfect integration of the switch panel, display element, proportional control, throttle lever, adjustable arm rests and dozer blade lever.

Maximum leg room. The large and leveled floor as well as the folding pedals guarantee the best space conditions in the most compact room and offer an additional foot rest.

Comfortable access and lots of space. The low access height on the left side and the control lever support that can be flipped up let you quickly take a seat in the comfort zone of the EZ17. All levers and switches can be reached easily.



The best panorama for working.

Because the B-column is eliminated and because of the standard top window, nothing dampens the clear view when working. EZ17 guarantees the perfect full 360-vision, also upward and downward and offers an extremely large field of vision. This way nothing will escape you. Especially for loading and unloading.

Regardless how versatile your tasks are, you will master them easy.



The EZ17 makes work simpler in all respects. You have the choice of different preparations and a complete hydraulic quick hitch system. EASY LOCK can also be combined perfectly with Powertilt. Get more out of your machine – completely efficiently and easily.

- Hydraulics and hydraulic quick hitch fork EASY LOCK as well as attachments are matched 100 %.
- Deliverable ex-works – no cost-intensive and laborious conversion work required.
- Higher machine productivity.
- Switch from one attachment to another in less than 30 seconds without the driver having to leave his cab.
- Reduced time and manpower needs.



Smart in use as backhoe and face shovel. With a simple turn the backhoe can be used as a face shovel. This not only saves time but also makes the excavator even more versatile in a clever way.

easylock

EZ17

Optional auxiliary control circuits. 3rd control circuit with tubing up to the end of the lifting arm control circuit for Powertilt and tubing up to the dipper arm end, control circuit for gripper, control circuit for hydraulic quick hitch system.

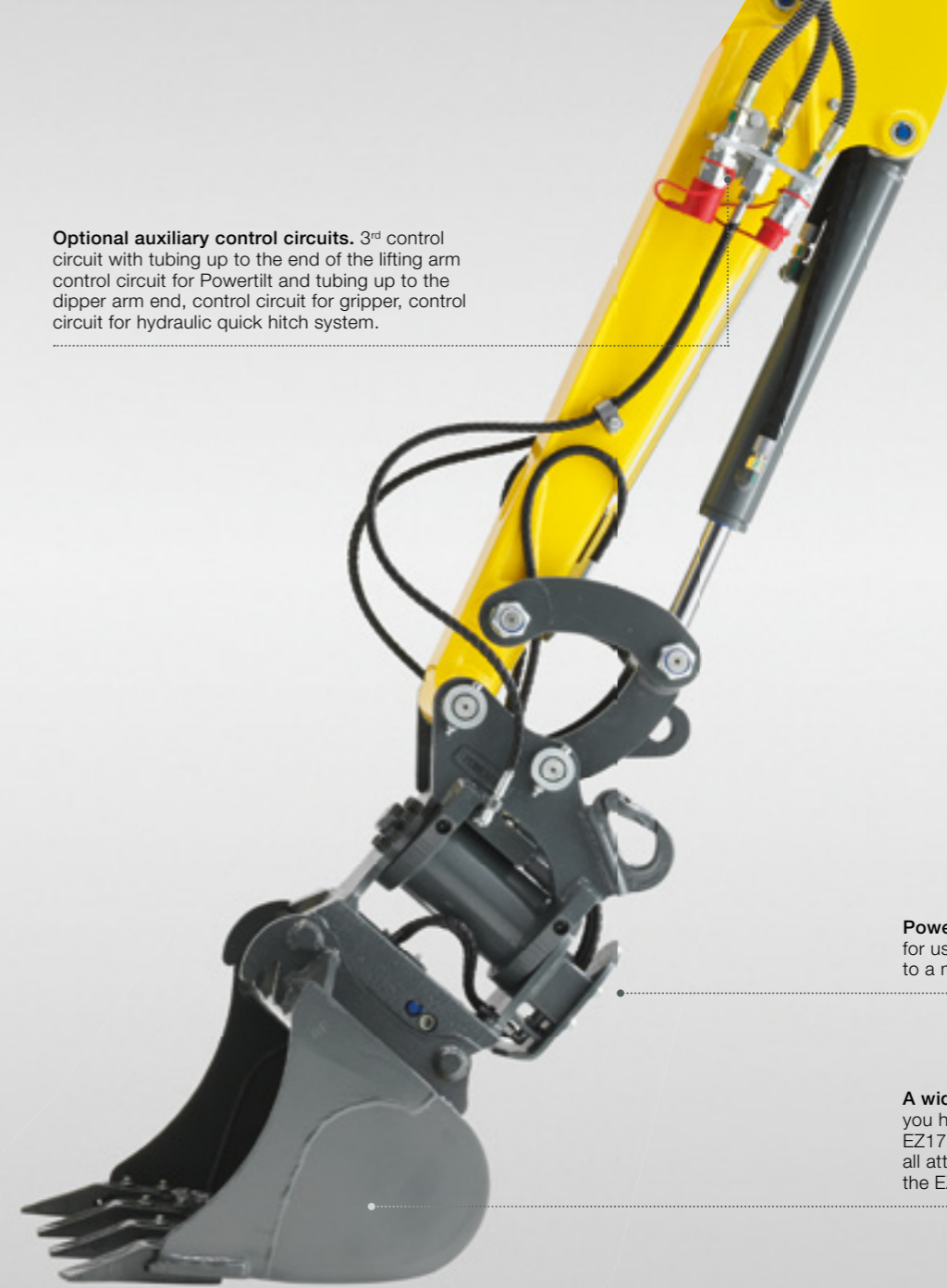

Powertilt and EASY LOCK. Expand the possibilities for use of the EZ17 and reduce the time spent to a minimum in the use on the construction site.

A wide range of attachments. Here as well, you have many options available that make the EZ17 a real all-round machine. Additional benefit: all attachments of the 1404 are compatible with the EZ17.

Adjusted to your working speed by one turn. The arm system and proportional control of the EZ17.

Completely individualized working: this is possible through the new continuous proportional control of the EZ17 for the auxiliary control circuits during operation. This provides individual control of the response behavior and the speed of the attachments.

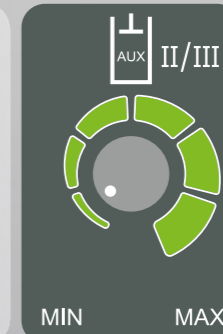

Technical data.

DIMENSIONS

A	Height mm	2,360
B1	Width of canopy mm	885
B2	Width of revolving superstructure mm	980
B3	Undercarriage width, retracted mm	990
B3	Undercarriage width, extended mm	1,300
C1	Transport length (short dipper arm) mm	3,585
C2	Transport length (long dipper arm) mm	3,550
D1	Max. digging depth (short dipper arm) mm	2,330
D2	Max. digging depth (long dipper arm) mm	2,490
E1	Max. vertical digging depth (short dipper arm) mm	1,715
E2	Max. vertical digging depth (long dipper arm) mm	1,865
F1	Max. digging height (short dipper arm) mm	3,465
F2	Max. digging height (long dipper arm) mm	3,580
G1	Max. dumping height (short dipper arm) mm	2,440
G2	Max. dumping height (long dipper arm) mm	2,550
H1	Max. span on the ground (short dipper arm) mm	3,850
H2	Max. span on the ground (long dipper arm) mm	4,000
K1	Max. digging radius (short dipper arm) mm	3,900
K2	Max. digging radius (long dipper arm) mm	4,050
M	Max. boom offset to centre of bucket, right side mm	535
N	Max. boom offset to centre of bucket, left side mm	425
O	Max. stroke height dozer blade above ground mm	390
P	Max. scraping depth dozer blade below ground mm	275
Q1	Distance bucket and depth dozer blade (short dipper arm) mm	332
Q2	Distance bucket and depth dozer blade (long dipper arm) mm	260
R1	Min. tail swing radius mm	650
R1H	Min. tail swing radius with additional rear weight mm	720
R2	Boom pivoting radius, center mm	1,625
R3	Boom pivoting radius, right mm	1,515
R4	Boom pivoting radius, left mm	1,370
S	Total crawler length mm	1,605
T	Crawler length, center to Turas guide wheel mm	1,225
W1	Max. swing angle, right °	57
W2	Max. swing angle, left °	65
X	Track width mm	230
Y1	Dozer blade width mm	990
Y2	Dozer blade width with expansion mm	1,300
Z	Dozer blade height mm	230

EZ17

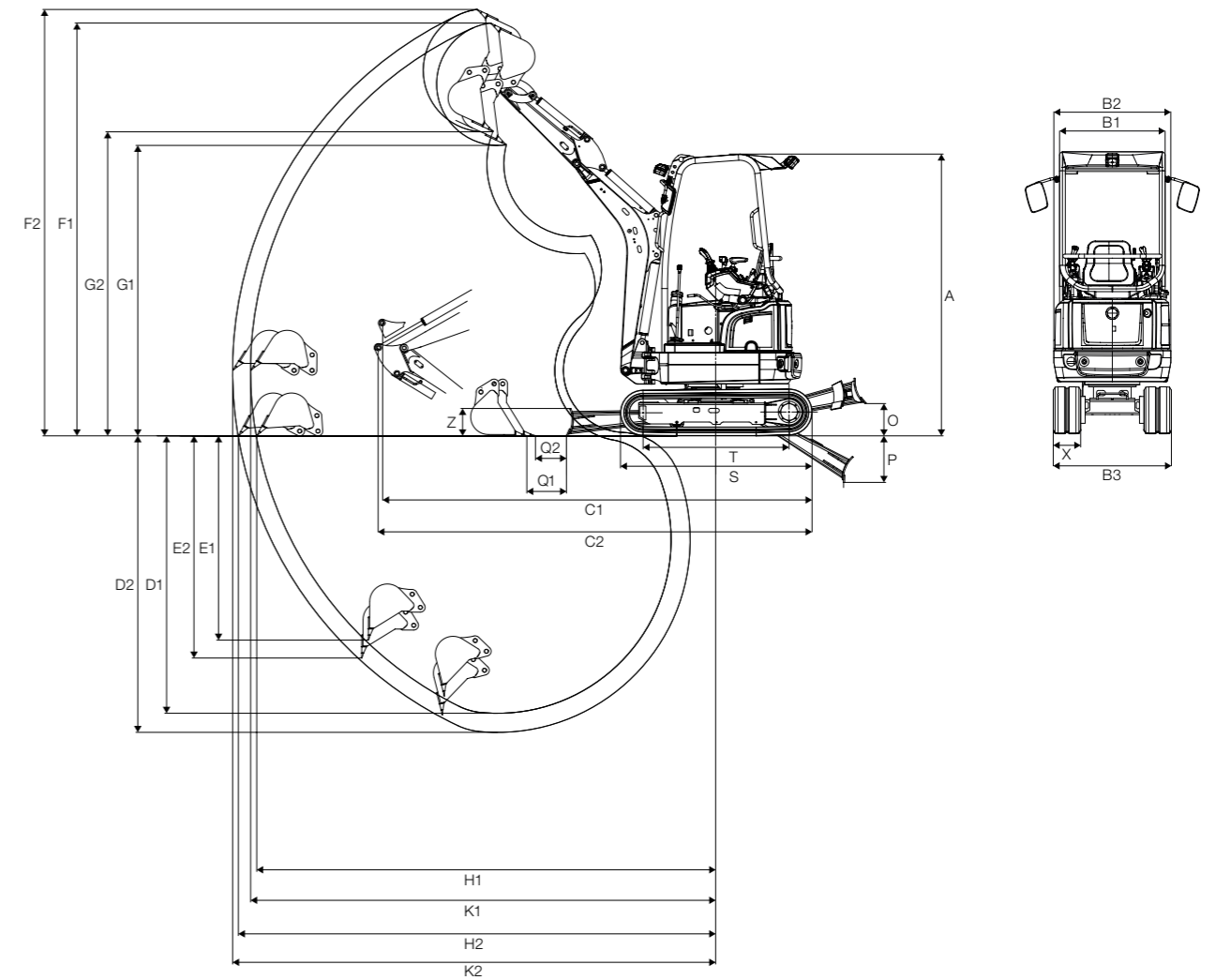
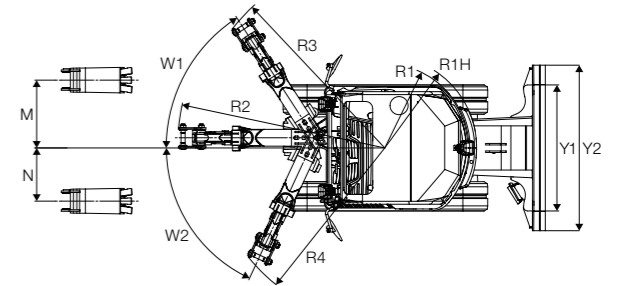

Technical data.

EZ17	
GENERAL	
Transport weight kg	1,595 – 1,765
Operating weight kg	1,725 – 1,895
ENGINE	
Model	Yanmar
Type	3TNV76
Construction	Liquid-cooled, 3-cylinder diesel engine
Displacement cm ³	1,116
Engine speed rpm	2,200
Engine output according to ISO kW	13.4
Battery voltage/capacitance V/Ah	12/30
HYDRAULICS	
Pumps	LUDV with variable displacement pump
Max. flow rate l/min	39.6
Operating pressure for working and driving hydraulics bar	240
Operating pressure for slewing gear bar	150
Superstructure slewing speed rpm	9.4
Max. max. tear-out force with short/long dipper arm KN	9.1/8.1
Max. breakaway force KN	18.7
UNDERCARRIAGE	
Track width mm	230
Ground pressure kg/cm ²	0.28
Number of track rollers pcs.	3
Ground clearance mm	160
Drive speed km/h	2.6/4.8
Max. gradeability °	58
DOZER BLADE	
Width x Height mm	990 x 1,300
Stroke above/below subgrade mm	275/390
CAPACITIES	
System filling with hydraulic oil l	21
Fuel tank l	22

Technical data.

LIFTING FORCE EZ17, SHORT DIPPER ARM										
	max		3.0 m		2.5 m		2.0 m		1.5 m	
	0°	90°	0°	90°	0°	90°	0°	90°	0°	90°
Ⓐ										
Ⓑ										
2.5 m	474*	302	–	–	469*	306	–	–	–	–
2.0 m	468*	231	–	–	431*	308	–	–	–	–
1.0 m	435*	182	491*	218	591*	291	781*	410	–	–
0.0 m	404*	179	493*	208	653*	271	916*	376	–	–
-1.0 m	384*	221	–	–	511*	269	705*	375	1,034*	602
-1.5 m	386*	293	–	–	–	–	540*	383	811*	614

LIFTING FORCE EZ17, LONG DIPPER ARM										
	max.		3.0 m		2.5 m		2.0 m		1.5 m	
	0°	90°	0°	90°	0°	90°	0°	90°	0°	90°
Ⓐ										
Ⓑ										
2.5 m	434*	264	–	–	375*	310	–	–	–	–
2.0 m	431*	209	423*	226	362*	310	–	–	–	–
1.0 m	405*	168	471*	218	549*	291	686*	414	–	–
0.0 m	380*	165	497*	206	655*	269	929*	373	–	–
-1.0 m	364*	198	385*	204	540*	264	745*	368	1,119*	591
-1.5 m	365*	251	–	–	413*	269	596*	375	903*	602

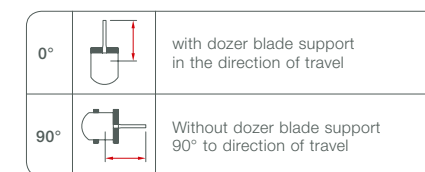

- Ⓐ** Projection from turnstile center
- Ⓑ** Load fixing height from ground level

* Lifting power is hydraulically restricted.

All table values are given in kg, in a horizontal position on a solid surface, without bucket and in telescopic extension of the transport gear (maximum transport gear width). If a bucket or other device is attached, the lifting power or lifting load is reduced by its own tare weight. Base of calculation: according to ISO 10567. The lifting force of the compact excavator is limited by the settings of the pressure relief valve and the tilt safety mechanism. Neither 75% of the static lifting load nor 87% of the hydraulic lifting power are exceeded.

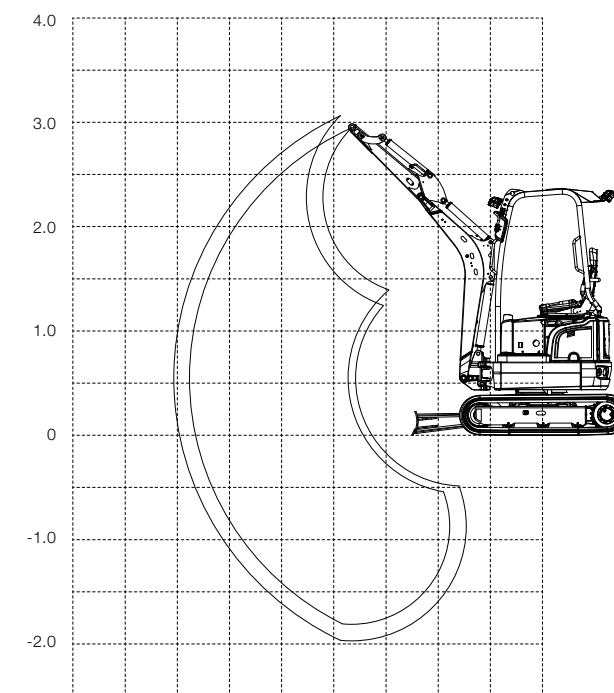

STANDARD EQUIPMENT	
General	Rubber chain 230 mm Dozer blade with foldaway expansions Work spotlight on the lifting arm Tool set including lubricant press and operating instruction
Engine	Water-cooled, 3-cylinder diesel engine
Canopy	Canopy meets the current ROPS, FOPS* and TOPS regulations Demountable with lifting eyes for lifting the machine on the canopy roof Top window in the front area Adjustable driver's seat with artificial upholstery and roll-up seat belt Document box
Hydraulics	Variable displacement pump with LUDV system Hydraulic servo control with joystick operation Valve control according to ISO, DIN, SAE, PCSA and EURO Additional hydraulic connections on the dipper arm for two movement directions Hydraulic oil cooler made of metal Miniature measurement connections
Undercarriage	Two driving speeds Hydraulic telescope transport gear 990 mm – 1,300 mm
OPTIONS	
Canopy	Weather protection FOPS - Level I roof protection grid Roof spotlight in front and back Mirror left and right Splinter protection Turning lamp
Hydraulics	AUXII: Auxiliary control circuit, proportional control by means of rocker switch on the joystick and adjustable capacity AUXIII: Like AUXII, tubing up to dipper arm end (Powertilt application) AUXIV: Control circuit for pendulum gripper (switching by means of ball valves for function of dipper cylinder or gripper) AUXV: Control circuit for hydraulic quick changer Comment: AUXII and AUXIII cannot be selected together Overload warning device with hose rupture safeguard, basic for lifting arm and dipper arm cylinder, advanced as well as basic and leak tight check valve for dozer blade cylinder Secondary pressure safety for auxiliary control circuits AUXI and AUXII/III Driving signal
Boom system	Long dipper stick
Paint	Special paint 1 RAL, yellow parts only Special paint 1 no RAL, yellow parts only Special paint for cabin/canopy RAL, only RAL color available
Miscellaneous	Additional rear weight (50 kg) Telematics Immobilizer system Service valve for engine oil pan Flat seal end, couplings
Security packages	Various warranty extensions
Assembled attachments	EASY LOCK EASY LOCK with Powertilt
Tool attachments	Various attachment buckets Hydraulics hammers

* FOPS (Level I or II) only available with additional protection grill – optionally ex factory or as retrofitting set.

Changes reserved without notice. Errors and omissions excepted. Only the contractual agreement is decisive.

Model overview.

TRACK EXCAVATORS

up to 1t	803
1-2t	1404, EZ17, ET18, ET20
2-3t	ET24, 2503, EZ28
3-4t	3503, 38Z3
4-5t	50Z3
5-6t	6003
6-8t	75Z3, 8003
12-14t	14504



MOBILE EXCAVATORS

up to 6t	6503
8-11t	9503



WHEEL DUMPERS

up to 2t	1001, 1501, 1601
2-5t	2001, 3001, 4001, 5001
6-9t	6001, 9001
over 9t	10001



TRACK DUMPERS

0.5t	DT05
0.8t	DT08, DT08 proline
1.2t	DT12
1.5t	DT15
2.5t	DT25



SKID STEER LOADER

443-567 kg	501s
613-726 kg	701s, 701sp
795-908 kg	901s, 901sp
1,035-1,170 kg	1101c, 1101cp



WACKER NEUSON WERK LINZ: MADE IN AUSTRIA, IN DEMAND WORLDWIDE.

The factory in Linz (AUT) it is the development and production site for compact excavators, mini-excavators, compact loaders (SSL), wheel dumpers and track dumpers. So many innovations that have made their triumphant way around the world started out right here.

PRODUCTION LOCATIONS OF THE WACKER NEUSON GROUP

- 1 Milwaukee, USA
- 2 Norton Shores, USA
- 3 Korbach, Germany
- 4 Pfullendorf, Germany
- 5 Reichertshofen, Germany
- 6 Linz, Austria
- 7 Kragujevac, Serbia
- 8 Manila, Philippines

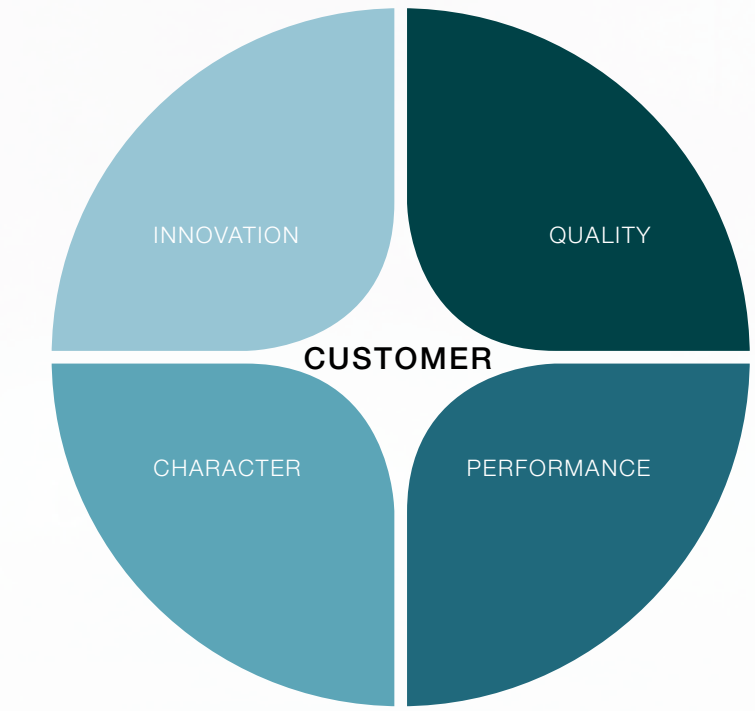

The vision and values wheel of Wacker Neuson: Customer success is at our center.

We win customers over with the values of a medium-sized and market-listed family-owned company. With the strength and expertise of a global organization. With people who fulfill our creed every day with life and ideas.

We believe in quality, innovation, performance and character. And the sustainable success of our customers, whom everything is ultimately about.

